



Stud Welding: A First Look



*Sunbelt Stud Welding, Inc.
6381 Windfern Road
Houston, TX 77040*

*713-939-8903
1-800-462-9353
www.sunbeltstudwelding.com*



STUD WELDING: A VERSATILE, ONE-STEP FASTENING SYSTEM

Stud welding is an arc welding process in which a fastener can be end-joined to a metal work piece instantaneously. It is a complete fastening system, using a wide variety of fasteners with literally thousands of uses – each permanently installed by one man, working on one side of the work piece, in less than one second.

It's quite a system and quite an improvement over other methods. Stud welding can cut your material and labor costs, improve structural reliability and appearance, and give you much greater design flexibility.

At Sunbelt Stud Welding, we understand that the kind of fastening system you specify can determine the efficiency of the entire manufacturing process. We have helped many manufacturers streamline production by improving their fastening operations. We want you to consider our stud welding systems as a solution to your fastening needs before a single design is committed to paper.

We at Sunbelt Stud Welding, Inc. want to earn your business. We are dedicated to dependability in design, engineering, manufacturing and service.

CAPACITOR DISCHARGE STUD WELDING SYSTEM

Capacitor Discharge (CD) Stud Welding is generally used to weld smaller diameter fasteners to thin base metals. Since the entire weld cycle is completed in milli-seconds, welds can be made without pronounced distortion, burn-through or reverse side discoloration. As long as one end of the fastener is designed for CD welding, CD studs can be manufactured in almost any shape.

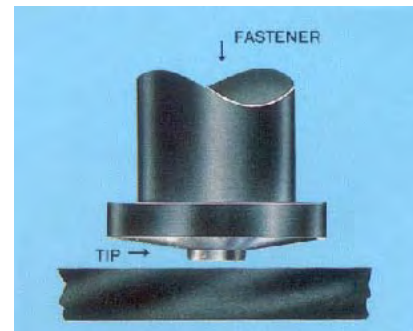

1) The fastener is placed against the work piece. Most CD studs have a special tip which provides precise weld-time control, for consistent, automatic welds.

ARC STUD WELDING SYSTEM

Arc Stud Welding is generally used to weld large diameter fasteners to rougher and thicker base metals. Arc studs may be almost any shape and there are literally hundreds, however, they must have one end of the fastener designed for Arc welding. Mild steel, stainless steel, and aluminum are applicable materials for Arc stud welding.

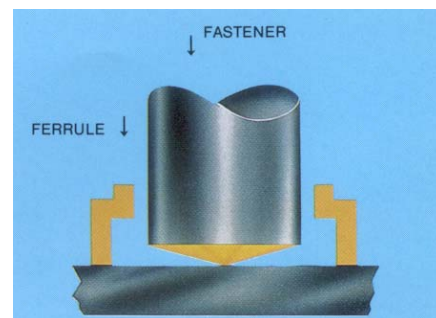

1) A fastener and ceramic ferrule are firmly placed against the work surface under spring tension.

HOW A FASTENER IS WELDED



LOAD

The fastener is manually or automatically inserted into the stud welder chuck.



POSITION

The fastener is positioned and brought into firm contact with the work surface.



FIRE

The fastener is welded in a fraction of a second. The weld develops full fastener strength instantaneously.



2) Weld gun is activated and stored energy is discharged through the fastener melting the full diameter of its base and a portion of the parent material.



3) Spring-loading forces the fastener into the molten metal.

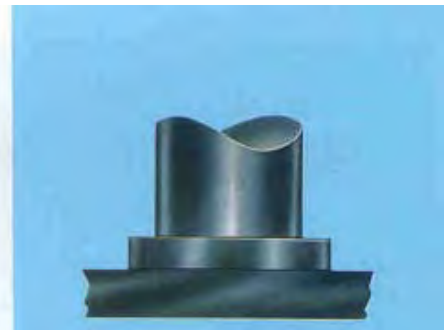

4) The fastener is held in place as the molten metal solidifies and instantly creates a high quality fusion weld.



2) Upon triggering, the weld gun automatically lifts the fastener from the base metal and initiates a controlled electric arc which melts the end of the fastener & a portion of the base metal.



3) A ceramic arc shield concentrates the heat and retains the molten material in the weld area for maximum weld strength and reliability.

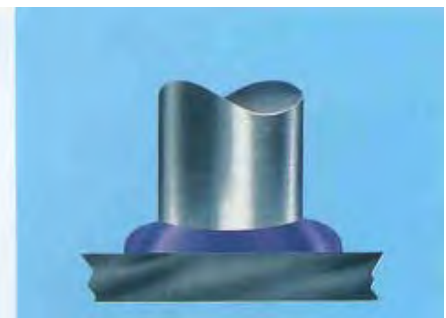

4) At the precise moment the fastener and parent metal become molten, the fastener is automatically plunged into the work surface. The metal solidifies and a high quality fusion weld is completed.



STUD - WELDING

UNIFORMITY & REPEATABILITY

Energy used to produce the weld is strictly monitored and precisely controlled by our welding equipment. The amount of energy used is always the same, making the welds consistently strong.

ATTRACTIVE APPEARANCE

The CD weld only penetrates a few thousandths of an inch, creating no burns or dimples on the reverse side. The fastener is surface-mounted to one side of the work piece thus eliminating ugly rivet heads, bolts, nuts and washers.

ALL TYPES OF METALS

Practically any metal can be adapted to stud welding. Aluminum, mild and stainless steel, copper, brass, and zinc are the most common metals used. However, exotics including titanium and inconel can also be used successfully in the stud welding process.

SPEED

High production – you can load, position, and weld up to 30 times a minute. As many as 1,800 studs can be fastened per hour using automatic equipment. The rate for portable equipment can be up to 1,000 studs per hour with the use of automatic bowl feeders.

ELIMINATION OF SECONDARY OPERATIONS

No need to drill or tap holes. No need to polish or grind surface metal. No rivet heads, bolts, nuts or washers; plus, elimination of the associated equipment and costs of these operations.

WELD STRENGTH – PERMANENCE AND INTEGRITY

Full fastener strength is developed. The weld is as strong as the fastener and the parent metal. Fastener will break or parent metal will fail before permanence of the weld quality. Also, you don't reduce the strength of the parent metal because there no holes, and with no holes, there are no leaks.

ACCURACY

Precise location of your stud welded fastener. With simple tooling, a location tolerance of $\pm .015''$ is standard with portable equipment. With bench-type equipment, standard tolerance is $\pm .010''$. A location tolerance of even $\pm .007''$ can be achieved with special equipment.

ONE MAN OPERATION

A single worker can fasten ARC or CD studs, whether the equipment is a portable gun or an elaborate piece of production equipment.

VARIETY OF FASTENERS

Select from a wide assortment of standard, in stock fasteners. We have a huge inventory, and if we don't have the one you need, we'll design and make it for you!



THE RIGHT FASTENING SYSTEM FOR YOUR APPLICATION NEEDS!



WHY STUD WELDED FASTENERS ARE BETTER

No drilling and tapping.
No cleanup.
No broken tools.
Won't vibrate loose.
No fillet.
Very fast, 5-6 milliseconds.

Flanged Nonflanged

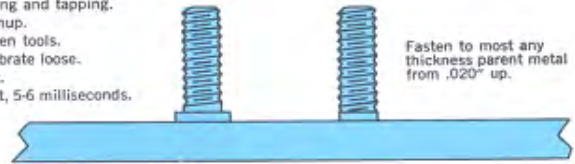

Fasten to most any thickness parent metal from .020" up.

Versatile, mobile, portable equipment or high speed automatic equipment can be used.

Reverse side can be painted, polished, vinyl-clad or otherwise finished before welding.

BETTER THAN RIVETS

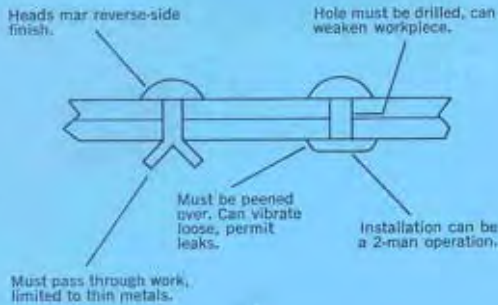

BETTER THAN NUTS AND BOLTS

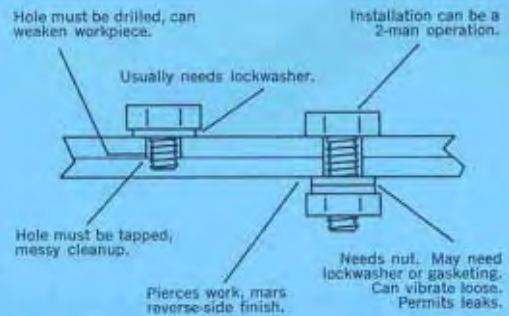

BETTER THAN RESISTANCE WELDING

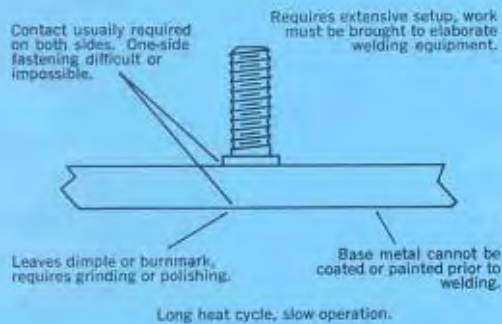

BETTER THAN SILVER SOLDERING OR BRAZING

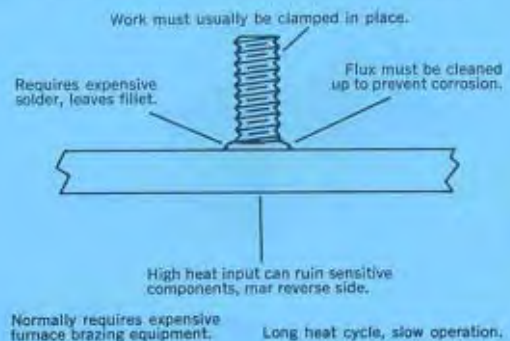



CD STUD LOAD STRENGTHS

STUD MATERIAL	STUD SIZE	MAXIMUM FASTENING TORQUE (Inch Lbs.)*	ULTIMATE TENSILE LOAD (Lbs.)	MAXIMUM SHEAR LOAD (Lbs.)
LOW-CARBON, COPPER FLASHED STEEL	6-32	6	500	375
	8-32	12	765	575
	10-24	14	960	720
	1/4-20	43	1750	1300
	5/16-18 3/8-16	72 106	2900 4300	2200 3250
STAINLESS STEEL: 304	6-32	10	790	590
	8-32	20	1260	940
	10-24	23	1530	1150
	1/4-20	75	2880	2160
	5/16-18 3/8-16	126 186	3750 4850	5350 7150
ALUMINUM ALLOY: 1100	6-32	2.5	200	125
	8-32	5	295	185
	10-24	6.5	380	235
	1/4-20	21.5	670	415
	5/16-18 3/8-16	36 53	1125 1660	695 1000
ALUMINUM ALLOY: 6061	6-32	6.5	350	160
	8-32	13	560	229
	10-24	19	670	310
	1/4-20	40	1240	679
	5/16-18 3/8-16	70.5 100	2025 2985	1210 1750
BRASS: 70-30 (260) 65-35 (268)	6-32	8	600	390
	8-32	16	860	560
	10-24	18.5	1040	680
	1/4-20	61	1950	1275
	5/16-18 3/8-16	102 150	3280 4800	2140 3160

**These values should develop fastener tension to slightly less than yield point.*

Disclaimer: *The provided performance data is intended as guideline specifications & strengths only and is based on assumptions of general and reasonable use. Performance suitability for any specific application should be determined by the user.*



ARC ENGINEERING SPECIFICATIONS AND LOAD STRENGTHS

These basic specifications are typical values of mechanical properties of Sunbelt studs. Also shown are the chemical properties of low carbon steel. For actual material analysis and physical properties, Sunbelt will provide, upon request, a detailed material certification.

STUD SIZE	SUGGESTED FASTENING TORQUE (INCH LBS)				ULTIMATE TENSILE STRENGTH (LBS)				ULTIMATE SHEAR LOAD (LBS)			
	LCS	HSS	304SS	5000 SA	LCS	HSS	304SS	5000 SA	LCS	HSS	304SS	5000 SA
8-32	17.8	-	19.8	-	1010	-	1260	-	750	-	940	-
10-24	20.8	-	22.8	10	1230	-	1530	770	920	-	1150	460
1/4-20	65	130	75.2	40	2300	3800	2880	1360	1720	2400	2160	850
5/16-18	129	260	132	70	3740	6200	4680	2300	2800	4000	3500	1400
3/8-16	212	400	236	81	5550	9300	6920	3250	4160	6000	5190	2100
7/16-14	338	-	376	140	7630	-	9600	4400	5710	-	7200	2400
1/2-13	465	900	517	-	10200	16900	12800	5950	7650	11000	9600	3000
5/8-11	1000	-	1110	-	16300	-	20200	-	12200	-	15150	-
3/4-10	1259	-	1530	-	24000	-	30000	-	18000	-	22500	-
7/8-9	1919	-	2328	-	33300	-	41600	-	24900	-	31200	-
1"-8	2832	-	3440	-	43600	-	54500	-	32700	-	40900	-

LCS (Low Carbon Steel):

- **Chemical Properties:** C-.23% Max.; P-.040% Max.; Mn-.90% Max.; S-.050% Max
- **Mechanical Properties:** Tensile Strength: 60,000 PSI Min.; Yield Strength: 50,000 PSI Min.; Elongation in two inches: 20% Min.
- **Mechanical Properties (Annealed):** Tensile Strength: 50,000 PSI, Yield Strength: 35,000 PSI; Elongation in two inches: 25%.

HSS (High Strength Steel):

- **Mechanical Properties:** Tensile Strength: 120,000 PSI Min.

304SS (Stainless Steel Type 302/304/305/316):

- **Mechanical Properties:** Tensile Strength: 85,000 PSI Min.; Yield strength: 40,000 PSI Min.; Elongation in two inches: 45%.
- **Mechanical Properties (Annealed):** Tensile Strength: 80,000; Yield strength: 30,000 PSI Min.; Elongation in two inches: 50%.

5000SA (Aluminum Alloy – 5000 Series):

- **Mechanical Properties:** Tensile Strength: 42,000 PSI Min.; Yield Strength: 30,000 PSI Min.

Disclaimer: The provided performance data is intended as guideline specifications & strengths only and is based on assumptions of general and reasonable use. Performance suitability for any specific application should be determined by the user.

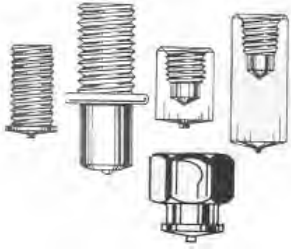

ELECTRONICS/AEROSPACE

Capacitor Discharge stud welding is ideal for the widest range of electronics and aerospace applications. CD studs can be welded to a variety of metals; including mild steel, stainless steel, aluminum, and exotics like titanium. You can weld to metal as thin as 1/32 of an inch with no reverse markings. Computers, audio-video equipment, keyboards, copy machines, control panels and more all lend themselves well to the speed and efficiency of CD stud welding.

COOKWARE/APPLIANCES

CD studs provide durable handle mounts for aluminum cookware. By using additional heads, our system offers the time-saving benefit of attaching multiple studs at lightning speed. The process eliminates tapping and drilling and prevents cosmetic imperfections while producing a reliable weld. Toasters, microwave ovens, blenders, sewing machines, and refrigerators are just a few of the other types of appliance applications where stud welding is found.

CD-212



CD-312



CDi-1502



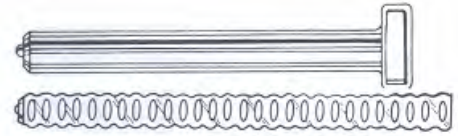

SIGNS AND DECORATIVE TRIM

Signs, name plates, automotive trim, plaques, door handles, and dozens of other decorative applications demand fasteners that will not appear on the face surface or distort it in any manner. CD stud welding eliminates distortions, dimples and burns on most metal surfaces. Even if the finish is vinyl-clad, enameled, coated, plated or polished, it will look just as good after a CD weld as it did before. Aesthetic appeal is preserved, so there is never a need for refinishing.

CONSTRUCTION

Sunbelt Stud Welding, Inc. supplies every type of stud and equipment needed for the construction industry. Headed concrete anchors provide known tensile and shear strength and can be applied in both the shop and the field. Our shear connectors reduced time and material cost when used in composite construction applications. Deformed bar anchors are used throughout the country because they don't distort angles or plates when used in prestressed and precast concrete construction.

CDi-1502



CDi-3102



IT-3002



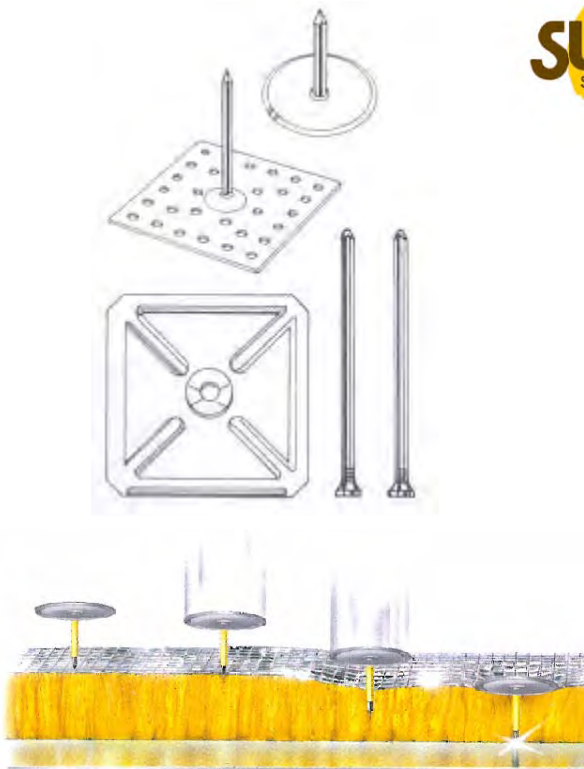

INSULATION PRODUCTS

Sunbelt Stud Welding, Inc. provides a wide range of products designed to simplify the permanent attachment of insulation to just about any kind of construction surface. Our weld pins, cuphead pins, spindles, self-stick anchors, nylon insul-anchors, and lacing anchors are a few of the insulation fasteners we supply for this special industry.

Pegasar-500

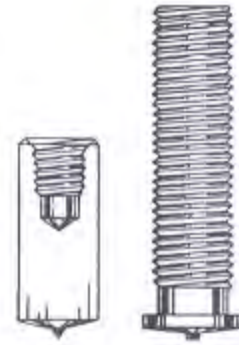

OFFICE FURNITURE

Metal furniture for offices, hospitals, schools and other institutions often call for a surface that is clear and clean with no exposed fastener heads. Stud welding is perfect for this application. All the work can be done from one side, by one man. Bolt heads are eliminated. The stud weld is permanent and strong...as strong as the stud and base metal themselves. Our Production Welders are CNC controlled for maximum production volume and efficiency.

Production Welder - CPW 0604



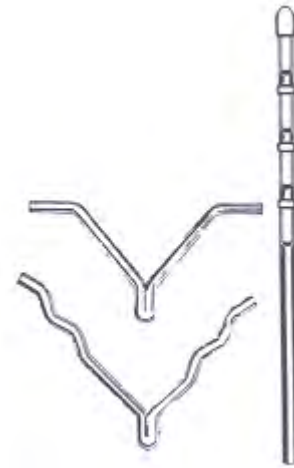
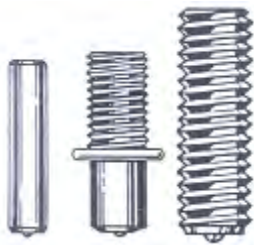

EQUIPMENT

Simpler designs, reduced costs, speedier production... these are some of the bonuses of using weld studs in the manufacturing of light and heavy duty equipment. In addition, stud welding eliminates time-consuming steps such as drilling, tapping, and through-bolting, while providing the advantage of one-sided fastening. Lawn mowers, snow blowers, tractors, forklifts and various power tools are several products that have unlimited stud welding applications.

REFRACTORY

Stud welding is often used in the Utility, Metalworking and Petrochemical Industries. Refractory anchors can be hand-welded or stud welded. If you want to secure blanket, castable, or gunited refractory material and you want to keep costs down, then you need one of our many refractory anchors. Because the basic function of any refractory anchoring system is to secure the refractory, Sunbelt anchors are constructed to hold up under the most adverse conditions.

IT-1002



VISAR-1200



IT-2002





MATERIAL HANDLING EQUIPMENT

Drilling and tapping are just two of the costly processes you can abandon when you use stud welding to build or repair various types of material handling equipment. In addition, stud welded fasteners provide rugged, vibration resistant fastening for conveyor systems that virtually eliminates the wear problems associated with other fastening methods

TRANSPORTATION AND SHIPBUILDING

Airplanes, nuclear submarines, automobiles and cruise liners can all take advantage of the stud welding process. At Sunbelt Stud Welding, our experienced sales personnel can help you determine which stud welding system will best meet your requirements.

ARC-656



IT-2002



ARC-1850





WIRE TIE DOWN

The Wire Tie Down Stud was created as an aesthetic and reliable alternative to traditional screw and adhesive fasteners. Because Wire Tie Down Studs are stud welded into place, eliminating the need for drilling holes, they provide a secure installation that will not break, loosen, or weaken over time. With a pull off that exceeds the capability of a typical 3/16" nylon strap, Wire Tie Down Studs are ideally suited for any wire assembly need from heavy duty construction equipment to wire management in industrial control boxes and telephone junction boxes.



HOME FURNISHINGS

Lamps and chandeliers can be crafted without any weld markings or fasteners that take away from the beauty of the piece. Sunbelt Stud Welding can design production stud welding equipment with features to match your particular requirements and needs. Patio furniture, brass beds, end tables and wall units are other furnishings that take advantage of stud welding.

CDi-2302



Production Welder MPW-2010/1010



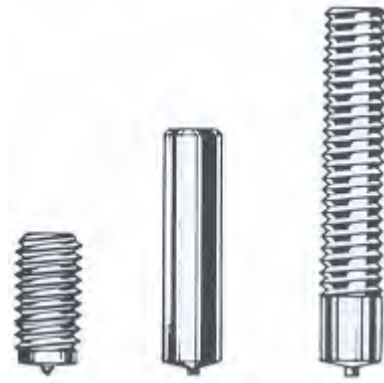
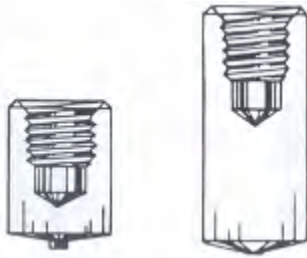

SPORTING GOODS

Not all forms of sports equipment require or can utilize welded fasteners. For the equipment that stud welding is applicable, the weld must be strong and inconspicuous. Exercise Equipment, golf clubs, skiing equipment, components of sail and motor boats, and canoes, all can be assembled faster and stronger with the aid of Sunbelt Stud Welding's production stud welding equipment.

TOYS

Whether it's a concerned parent doing the buying, a consumer agency inspecting the quality or a child testing out its durability; toys must not only be attractive but must meet rigid safety requirements. Sunbelt Stud Welding's line of production equipment is the most efficient and precise way to fasten such products as bicycles, wagons, trucks, outdoor swings, and a host of other toy products.

Production Equipment - MPW 2010/1010





MARINE CABLE HANGERS

Marine cable hangers are used to secure cable runs on ships and offshore rigs. There are a variety of styles available, depending on your requirements. Every type of cable hanger easily installs on a 3/8" diameter weld stud. This method of securing electrical cable has withstood the test of time, maintaining its integrity through vibration, corrosion, and incidental impact for the life of the rig or vessel. A few of the different types of cable hangers are pictured below. For a complete listing of all cable hangers, please contact Sunbelt Stud Welding, Inc. and ask to speak to a customer service representative.

Slotted Cable Hanger

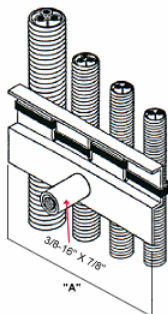

Crimp Type Cable Hangers

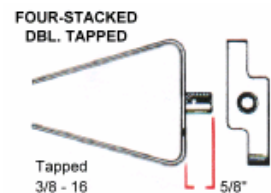
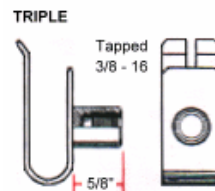
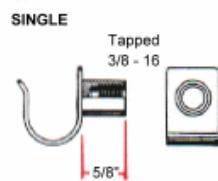

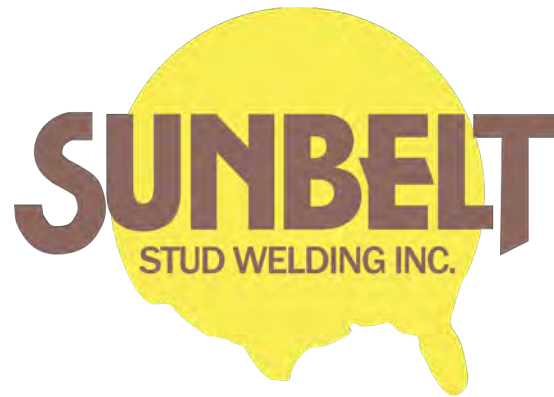

The applications are endless!

Products and Services

PRODUCTS

Arc Studs
Capacitor Discharge Studs
Headed Anchors
Deformed Bars
Tapped Pads
Insulation Pins
Insulation Clips
Refractory Anchors
Cable Hangers
Pipe Hangers
Threaded Studs
Non-Threaded Studs
Bi-metallic
Navy Caps MS/SS
Boiler Studs
Collar Studs
Eyebolt Studs
Spanner Nuts
Anti Skid Studs
Custom Made Studs
Parts & Accessories

SERVICES

Service
Repairs
Technical Assistance
Application Development

EQUIPMENT

New Arc Equipment
New CD Equipment
Production Equipment
Reconditioned Equipment
Large Rental Fleet
Field Diesels